

# Temposonics®

Magnetostrictive Linear-Position Sensors



M-Series Mobile Equipment Sensor  
Model MS  
Analog Output

551026 C

## Product Specification



M-Series (Model MS)  
analog output sensor



M-Series (Model MS) sensor with analog output  
(shown in cylinder application)

### Features

- **Compact Design for Embedded Cylinder Applications**  
28 mm (1.1 in.) Diameter Housing Installation in  
38 mm (1.5 in.) Bore Cylinder
- **Linear, Absolute Position Sensors**
- **Non-contact Sensor Technology**
- **Superior Accuracy: Linearity < +/- 0.04% F.S.**
- **Repeatability: < ± 0.005% F.S.**
- **No External Electronics**
- **Analog Output: 0.25 - 4.75 Vdc, 0-20 mA, 4-20 mA**
- **Sensor Stroke Length: 50 mm (1.97 in.) - 2000 mm (79 in.)**
- **Power Supply: 12 Vdc**
- **Shock Rating: 100 g (single hit) / IEC 68-2-27**
- **Vibration Rating: 25 g / 10-2000 Hz / IEC 68-2-6**
- **100 V.m EMI Immunity**

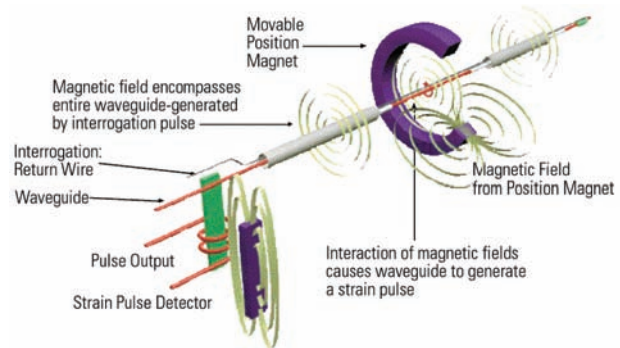

### Product overview

Today's buyers are more concerned with greater productivity, lower overall operating costs and cost of ownership. Temposonics M-Series Mobile Equipment sensors help lower overall costs by increasing safety and versatility, increasing reliability and reducing service costs. Temposonics Mobile Equipment sensors are designed specifically for position sensing applications in rugged environments typically encountered by construction, agriculture and other off-highway machinery. All Temposonics Mobile Equipment sensors utilize magnetostrictive technology.

The M-Series, Model MS sensor with analog output, is one of the latest compact stainless-steel position sensors specifically designed for use in welded and tie-rod style cylinders, or any space limited cylinder application. The M-Series Model MS sensor is an ideal choice for a wide range of standard hydraulic cylinders with diameters of 50 mm (1.97 in.) or larger.

The extremely rugged model MS sensor consists of the following main components:

1. The sensor head; A robust housing with built-in electronics.
2. The pressure-proof sensor pipe; The sensor pipe houses and protects the internal sensing element.
3. The position magnet; The magnet is mounted on the piston, during operation it travels along the stationary sensor tube. This sensor system is "non-contact" by design.

### Benefits of magnetostrictive sensing

Temposonics linear-position sensors use the time based magnetostrictive position sensing principle developed by MTS. Within the sensing element, a sonic strain pulse is induced in a specially designed magnetostrictive waveguide by the momentary interaction of two magnetic fields. One field comes from a movable permanent magnet that passes along the outside of the sensor. The other field comes from an "interrogation" current pulse applied along the waveguide. The resulting strain pulse travels at ultrasonic speed along the waveguide and is detected at the head of the sensing element.

The position of the magnet is determined with high precision and speed by accurately measuring the elapsed time between the application of the interrogation pulse and the arrival of the resulting strain pulse with a high-speed counter. Elapsed time is used to determine the permanent magnet position which provides an absolute position reading that never requires recalibration or re-homing after a power loss. Non-contact sensing eliminates wear, and guarantees the best durability and output repeatability.

All specifications are subject to change. Contact MTS for specifications and engineering drawings that are critical to your application. Drawings contained in this document are for reference only. Go to [www.mtssensors.com](http://www.mtssensors.com) for the latest support documentation.

## Product specifications and dimensions

### Temposonics Model MH high-pressure compact sensor

M-Series sensors were designed with the “mobile” world in mind, and have been validated in the field by customers worldwide. Performance is second-to-none; high accuracy, repeatability, 100 V/m EMI, and position output.

Ruggedness is “designed in”; 100 g shock and 15 g vibration rating. Cable and wire options are sized for direct connection to industry proven connectors. The model MS sensor is fully sealed and when embedded in a cylinder provides a long operating life.

Parameters	Specifications
<b>Measured variations:</b>	Displacement
<b>Resolution:</b>	Infinite, restricted by output ripple
<b>Linearity, uncorrected:</b>	$\leq \pm 0.04\%$ F.S. (minimum $\pm 0.100$ mm (0.003 in.))
<b>Repeatability:</b>	$\leq \pm 0.005\%$ F.S.
<b>Update frequency:</b>	> 488 Hz
<b>Ripple:</b>	< 0.04% F.S.
<b>Stroke length:</b>	50 mm (1.97 in.) - 2000 mm (79 in.) in 5 mm (0.19 in.) increments
<b>Outputs:</b>	Analog: 0.25-4.75 Vdc, 0-20 mA, 4-20 mA, output range factory programmable through entire stroke, fully reversible.
<b>Operating temperature:</b>	-40 °C (-40 °F) to 105 °C (221 °F) (sensor)
<b>Dew point, humidity:</b>	90% rel. humidity, no condensation

Parameters	Specifications
<b>Sealing:</b>	IP 67 (cable exit)
<b>Rod pressure ratings</b> <b>7 mm (0.27 in.) rod:</b>	300 bar (4351 psi) operating, 450 bar (6526 psi) peak pressure
<b>Electrical connection:</b>	3-wire pigtailed PUR cable
<b>Voltage input:</b>	12 Vdc (10 to 16 Vdc)
<b>EMI tests:</b>	100 V/m: ISO 11452-5, IEC 61000-6-1/2 - CE
<b>Shock ratings</b> <b>7 mm (0.27 in.) rod:</b>	100 g (single hit) /IEC 68-2-27
<b>Vibration ratings</b> <b>7 mm (0.27 in.) rod:</b>	15 g/10-2000 Hz/IEC 68-2-6
<b>Current drain:</b>	80 mA typical
<b>Electrical isolation:</b>	500 Vdc (DC ground to machine ground)
<b>Polarity protection:</b>	Up to -36 Vdc
<b>Overvoltage protection:</b>	Up to 36 Vdc
<b>Sensor material:</b>	Stainless steel 1.4301/AISI 304

### Temposonics Model MS sensor dimensions

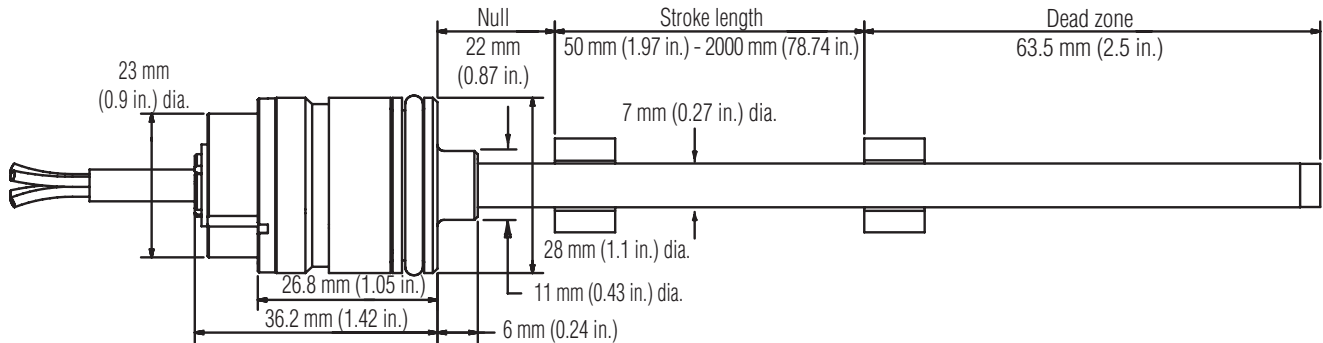

#### Notes:

Contact factory for tolerance drawing and cavity detail.

## Installation, wiring examples and magnets

The robust Temposonics Model MS sensor's compact size is well suited for direct stroke measurement in standard compact hydraulic cylinders. The Temposonics Model MS sensor can be installed from the head side or the rod side of the cylinder depending on the cylinder design.

### Sensor installation

The method of installation is entirely dependent on the cylinder design. While the most common method of installation is from the rod side of the cylinder, installation from the head side of the cylinder is also possible. In both installation methods, the sensor seals the cylinder by using an O-Ring and backup ring which is installed on the sensor housing.

### Temposonics Model MS sensor installation examples

#### Rod-side installation

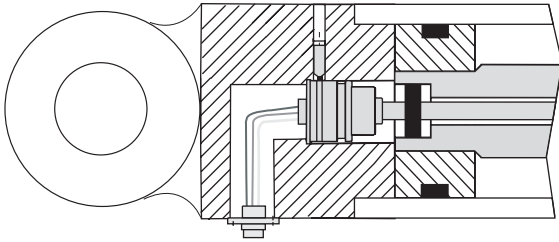

#### Cylinder head, side installation

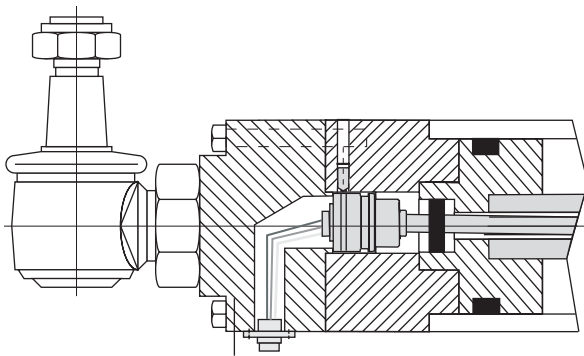

**Retaining screw with set screw DIN 914  
M5 x 10 maximum torque 0.5 Nm  
(0.369 lbf-ft. / 4.43 lbf-in.) or  
UNF/UNC equivalent**

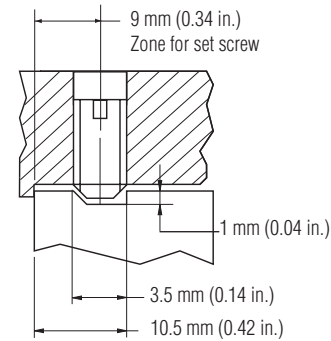

**Detail f ange housing**

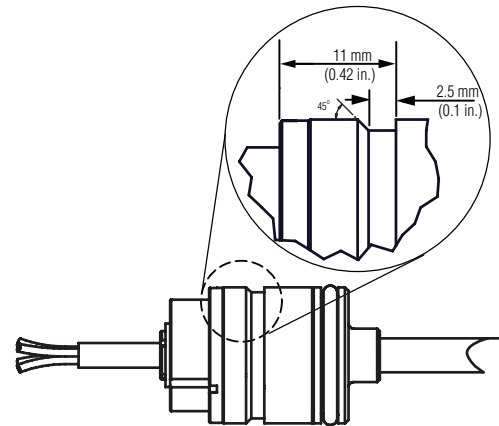

### Wiring diagram (standard configuration)

Wire color	Signal
Green	Position output
Brown	12 Vdc
White	DC ground (0 Vdc)
Yellow	Not used

### Position magnets

#### Part no. 201542-2

Temperature:  
-40°C (-40 °F) to  
105 °C (221 °F)  
Material: Ferrite PA

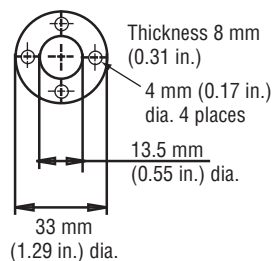

#### Part no. 400633

Magnet spacer  
(use with magnet  
part no. 201542-2)

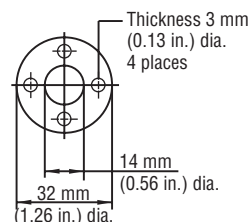

#### Part no. 400533

Temperature:  
-40°C (-40 °F) to  
105 °C (221 °F)  
Material: Ferrite PA

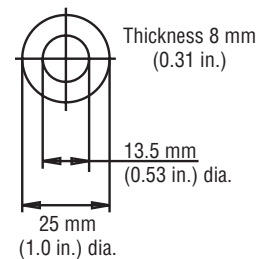

#### Part no. 401032

Temperature:  
-40°C (-40 °F) to  
105 °C (221 °F)  
Material: Ferrite PA

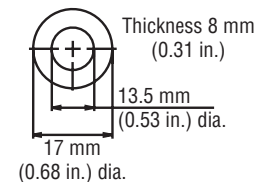

## How to order and accessories

When placing an order, build the desired model number using the model number guide (below). If you have any questions about how to apply a model MS position sensor to your specific application, please contact MTS Applications Engineering.

	M	S					M				A	3			
	1	2	3	4	5	6	7	8	9	10	11	12	13	14	15
<b>MS</b>	=		<b>SENSOR MODEL</b>												
			Hydraulic rod-style 7 mm (0.27 in.) dia. housing												
---	M	=	<b>STROKE LENGTH (order length)</b>												
			Millimeters (50 mm) (1.97 in.) to 2000 mm (79 in.) in 5 mm (0.19 in.) increments												
T	--	=	<b>CABLE EXIT / CONNECTION TYPE</b>												
			Cable exit:												
			4 conductor / cable; Integral TPE cable, pigtail, 4 cables 24 AWG, shielded.												
			Cable length (first digit x m, second digit x 0.1 m)												
			<b>10</b> = 1 m length (standard, all other lengths require minimum order quantities; 0.5 m min. - 9.9 m max; 0.1 m increments)												
A	=	<b>CABLE TERMINATION OPTION</b>													
		Pigtail (stripped conductors)													
		(Note: For wire termination, please consult the factory)													
3	=	<b>INPUT VOLTAGE</b>													
		+ 12 Vdc, tolerance 10 - 16 Vdc													
V11	=	<b>OUTPUT</b>													
V12	=	Voltage:													
V13	=	0.25-4.75 Vdc													
V14	=	0.5-4.5 Vdc													
A01	=	4.75-0.25 Vdc													
A03	=	4.5-0.5 Vdc													
		Current:													
		4-20 mA													
		0.20 mA													

Accessories	
Description	Part no.
Ring magnet	201542-2
Ring magnet	400533
Ring magnet	401032
Magnet spacer (use with magnet part no. 201542-2)	400633



Part Number: 03-08 551026 Revision C  
 MTS and Temposonics, and are registered trademarks of MTS Systems Corporation.

All other trademarks are the property of their respective owners.  
 All Temposonics sensors are covered by US patent number 5,545,984. Additional patents are pending.  
 Printed in USA. Copyright © 2008 MTS Systems Corporation. All Rights Reserved in all media.



### UNITED STATES

**MTS Systems Corporation  
Sensors Division**

3001 Sheldon Drive  
 Cary, NC 27513  
 Tel: (800) 633-7609  
 Fax: (919) 677-0200  
 (800) 498-4442  
 www.mtssensors.com  
 sensorsinfo@mts.com

### GERMANY

**MTS Sensor Technologie  
GmbH & Co. KG**

Auf dem Schüffel 9  
 D - 58513 Lüdenscheid  
 Tel: +49 / 23 51 / 95 87-0  
 Fax: +49 / 23 51 / 56 491  
 www.mtssensor.de  
 info@mtssensor.de

### JAPAN

**MTS Sensors Technology  
Corporation**

Ushikubo Bldg.  
 737 Aihara-cho, Machida-shi  
 Tokyo 194-0211, Japan  
 Tel: +81 (42) 775 / 3838  
 Fax: +81 (42) 775 / 5516  
 www.mtssensor.co.jp  
 info@mtssensor.co.jp